

PRODUCT FEATURES

CONSTRUCTION

- 12MM MARINE GRADE BIRCH PLYWOOD WITH HPL EXTERIOR

NOTES:
UNLESS SPECIFIED IN THE DRAWING,
ALL PRODUCTS DISPLAYED IN THIS
DRAWING OTHER THAN THE PANELS
AND EXTRUSIONS ITSELF IS NOT PART
OF OUR PRODUCT OFFERING.

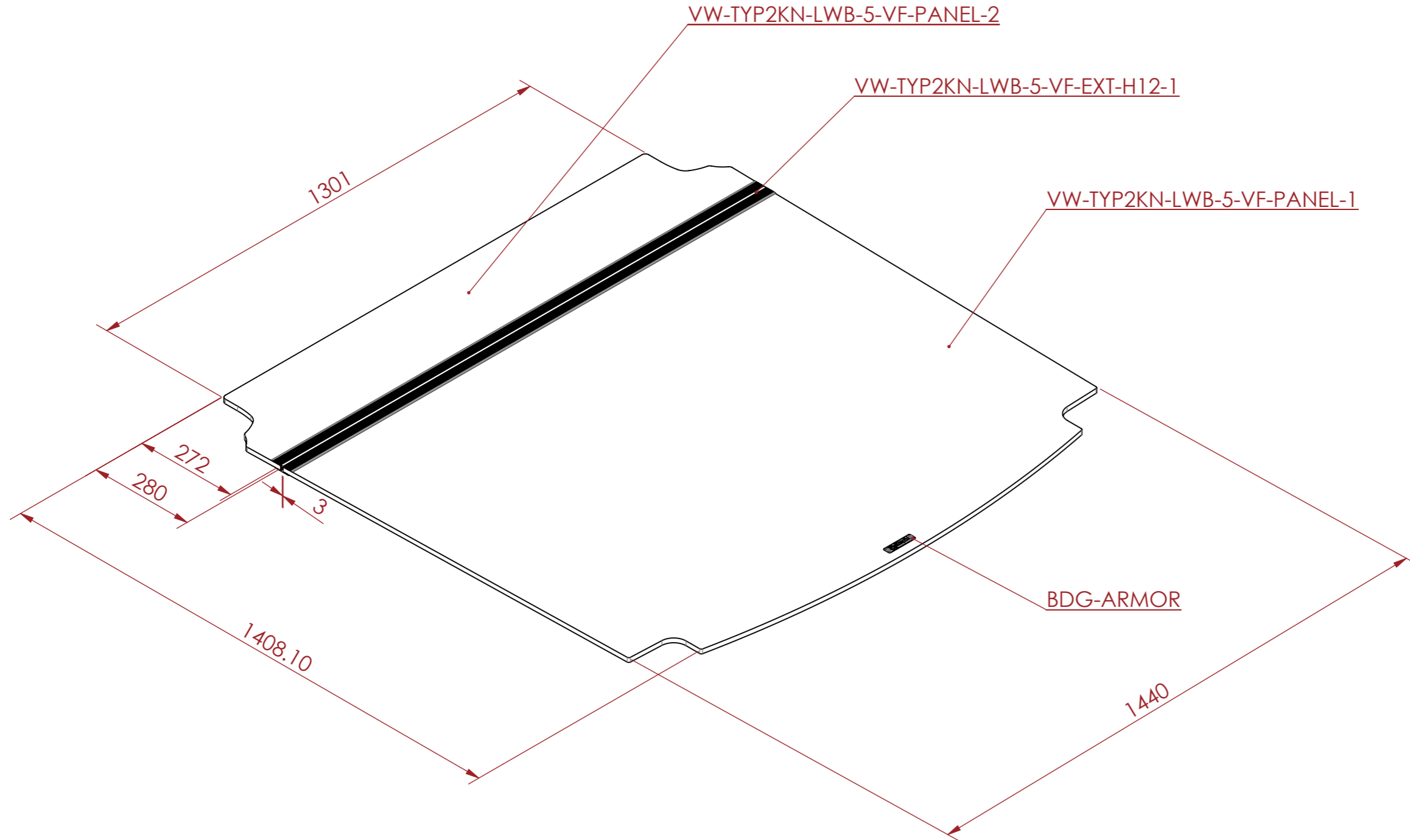

INSTALLATION COST:
107.15 AUD

ESTIMATED WEIGHT :
18.3 KG

ITEM CODE:
VW-TYP2KN-LWB-5-VF

DRAWN BY: KA CHECKED BY: AS

SCALE:
NTS



MAIL : sales@armorcases.com.au
WEB : www.armorcases.com.au