

PRODUCT FEATURES

CONSTRUCTION

- 12.7 mm WBP-Grade Laminated Birch Plywood flooring with a heavy-wearing, anti-slip HPL surface, designed for durability in commercial use
- HJ-12 Aluminium panel joiner extrusion (2 mm thick) used to securely join floor panels and maintain a neat, sealed finish
- 2 mm aluminium edge extrusion to protect exposed edges and high-traffic floor areas
- Aluminium rear step extrusion to protect the rear loading edge of the floor from impact and wear
- Pre-drilled 5 mm holes for Rivets which enable refitting after flooring installation, ensuring a clean, smooth finish without large cut-outs.

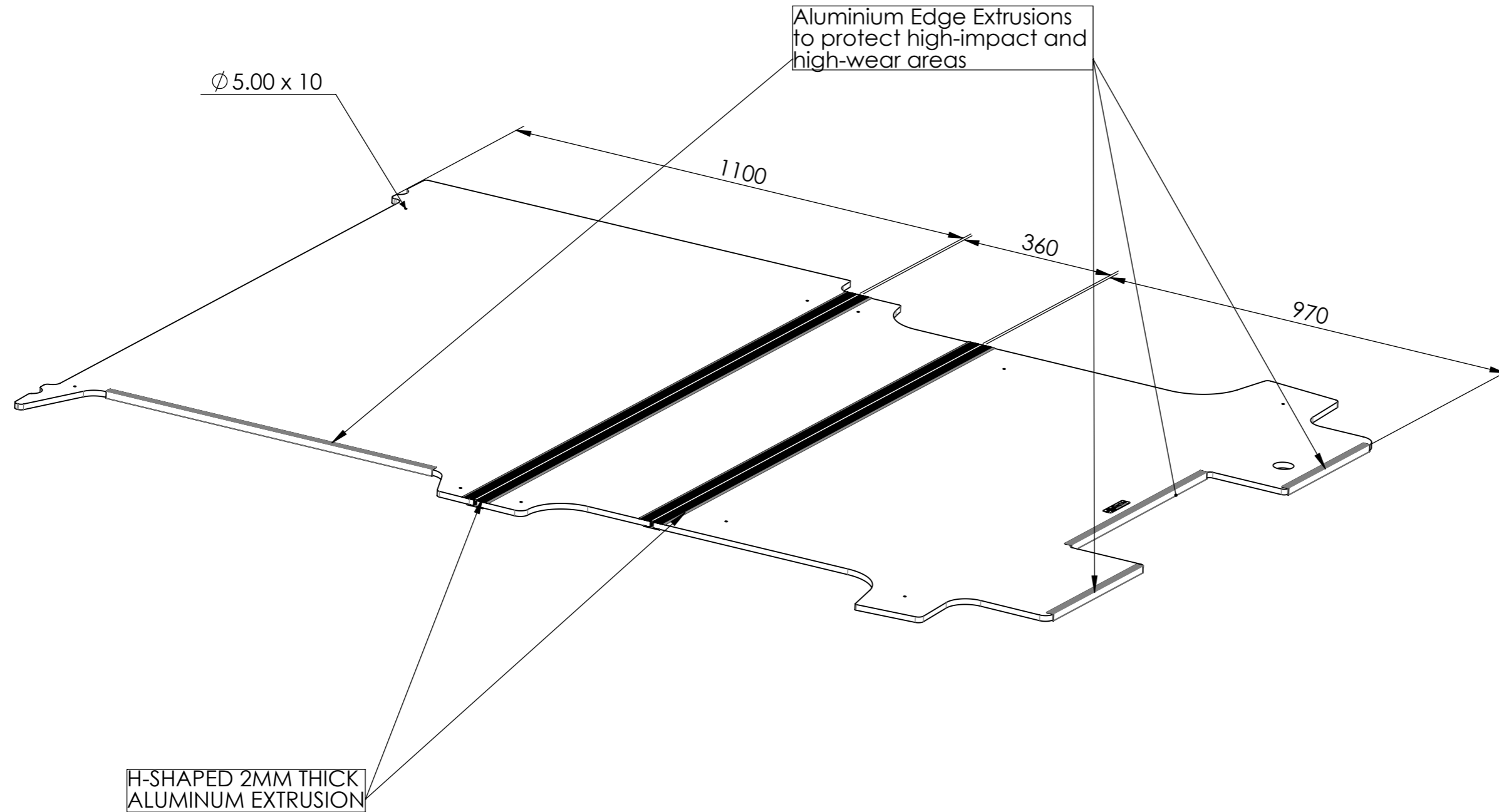

ESTIMATED WEIGHT :	
31.37 KG	
ITEM CODE:	
FD-320S-II-SWB-5P-VF	
DRAWN BY:	CHECKED BY:
KA	AS
SCALE:	
NTS	



MAIL : sales@vanlining.com.au
WEB : www.vanlining.com.au